

 **KENWOOD**

HF SSB TRANSCEIVER

Model TS-120V



OPERATING MANUAL

Downloaded by

Amateur Radio Directory

You are the new owner of our latest product, the new TS-120V Transceiver. Before using, please read this instruction manual carefully to ensure correct operation. The unit has been carefully engineered and manufactured to rigid quality standards, and should give you satisfactory and dependable operation for many years.

CONTENTS

| | |
|---------------------------------------|-------|
| SPECIFICATIONS | 3 |
| SECTION 1. FEATURES | 4 |
| SECTION 2. BEFORE USING | 4 |
| 2.1 ACCESSORIES | |
| 2.2 INSTALLATION | |
| 2.3 CONNECTION | |
| 2.4 ANTENNA AND POWER SUPPLY | |
| SECTION 3. CONTROLS..... | 6 |
| 3.1 FRONT PANEL | |
| 3.2 REAR PANEL | |
| SECTION 4. OPERATION | 9 |
| 4.1 RECEPTION | |
| 4.2 TRANSMISSION | |
| 4.3 VOX OPERATION | |
| 4.4 SEMI-BREAK-IN OPERATION | |
| 4.5 FIXED CHANNEL OPERATION | |
| 4.6 CW OPERATION | |
| 4.7 MOBILE OPERATION | |
| 4.8 FIXED STATION OPERATION | |
| 4.9 CALIBRATION OF COUNTER FREQUENCY | |
| 4.10 CALIBRATION OF MAIN DIAL SCALE | |
| SECTION 5. ACCESSORIES (OPTION) | 18 |
| BLOCK DIAGRAM..... | 19 |
| SCHEMATIC DIAGRAM..... | 20~23 |
| PARTS LAYOUT | 24 |

TS-120V SPECIFICATIONS

| | | |
|--------------------------------|--|---------------------------------------|
| Frequency Range | 80 meter band | 3.5 ~ 4 MHz |
| | 40 meter band | 7 ~ 7.3 MHz |
| | 20 meter band | 14 ~ 14.35 MHz |
| | 15 meter band | 21 ~ 21.45 MHz |
| | 10 meter band A | 28 ~ 28.5 MHz |
| | 10 meter band B | 28.5 ~ 29 MHz |
| | 10 meter band C | 29 ~ 29.5 MHz |
| | 10 meter band D | 29.5 ~ 29.7 MHz |
| | WWV | 15.0 MHz (reception only) |
| Mode | USB, LSB or CW | |
| Power Voltage | 12 ~ 16V DC (standard: 13.8V) | |
| DC Current | Transmit | 4A (VSWR: 1 : 1.5 or less) |
| | Receive | 0.7A |
| (at DC 13.8V) | | |
| RF Output Power | 10 watts | |
| Audio Input Impedance | 500 Ω ~ 50k Ω | |
| Audio Output | More than 1.5 watts (with less than 10% distortion) into an 8 ohm load. | |
| RF Output Impedance | 50 Ω | |
| Frequency Stability | Within 100 Hz during any 30 minute period after warmup | |
| | Within \pm 1 kHz during the first hour after 1 minute of warmup | |
| Audio Frequency Response | 400 to 2,600 Hz, within \pm 6 dB | |
| Carrier Suppression | Carrier better than 40 dB down from the output signal | |
| Spurious Radiation | Better than 40 dB down from the output signal | |
| Sideband Suppression | Unwanted sideband is better than 50 dB down from the output signal | |
| Image Ratio | Image frequency better than 50 dB down from the output signal | |
| IF Rejection | IF frequency is 70 dB or more down from output signal | |
| Receiver Sensitivity | 0.25 μ V S + N/N 10 dB or more | |
| Receiver Selectivity | SSB, CW | 2.4 kHz bandwidth (\pm 6 dB down) |
| | | 4.2 kHz bandwidth (\pm 60 dB down) |
| Semiconductors | IC | 26 |
| | FET | 16 |
| | Transistor | 84 |
| | Diode | 138 |
| Dimensions | 241 (241) W \times 94 (108) H \times 235 (281) D mm | |
| | Figures in (): Projections included | |
| Weight | Approx. 4.9 kg | |

* Specifications are subject to change without notice for technical improvement.

SECTION 1. FEATURES

1. SINGLE CONVERSION SYSTEM WITH PLL CIRCUIT

The adoption of a single conversion system with unique PLL (Phase Locked Loop) circuit, FET balanced type mixer and MOS FET assures excellent spurious characteristics and 2-signal characteristic.

2. BUILT-IN DIGITAL DISPLAY

The digital display permits easy reading of operating frequency to an accuracy of 100 Hz on any band and any operating mode.

3. BUILT-IN IF SHIFT CIRCUIT (Pass band Tuning)

An IF SHIFT system is built in to the transceiver to allow shifting of IF passband, thereby eliminating adjacent channel interference.

4. 3.5 ~ 29.7 MHZ AND WWV BANDS

The transceiver is designed to operate on LSB/USB/CW in the bands 3.5 ~ 29.7 MHz. WWV band (14.5 ~ 15 MHz) is also built in to the transceiver to permit accurate frequency calibration.

5. COMPACT, LIGHT-WEIGHT DESIGN

The TS-120V has many advanced features, yet it is compact and light-weight; suitable for mobile and field operations as well as fixed station operation.

6. EASY OPERATION

All controls and switches are carefully arranged for ease of operation, ensuring optimum transmission and reception.

7. ALL SOLID-STATE DESIGN

The all solid-state, compact unit features a wide band final stage, eliminating the need for frequency tuning during use.

8. FOUR FIX CHANNELS

Four FIX channels can be installed, one channel for each of 7, 14, 21 and 28 MHz bands. FIX channels in 3.5 MHz and 28 MHz can be selected simply by using a connector on the chassis. This facility is particularly useful in mobile and net operation.

9. FULL RANGE OF AUXILIARY FUNCTIONS

The TS-120V is equipped with a VOX circuit, a balanced gate system noise blanker circuit to minimize pulse noise, and a 25 kHz marker.

10. INSTALLATION OF CW FILTER YK-88C

The TS-120V permits the use of the option CW filter YK-88C. CW semi-break-in operation is provided using the built-in VOX circuit and CW side tone oscillator.

11. WIDE VARIETY OF OPTIONAL ACCESSORIES

The following accessories are available as optional extra: Power Supply Regulator (PS-20), Mobile Mount (MB-100), CW Filter (YK-88C), External VFO (VFO-120), External Speaker (SP-120).

SECTION 2. BEFORE USING

2.1 ACCESSORIES

The following accessories are furnished with the TS-120V:

| | |
|------------------------|---|
| Operating manual | 1 |
| Microphone plug | 1 |
| Speaker plug | 1 |
| 7P DIN plug | 1 |
| DC power cord | 1 |
| Fuse | 1 |

2.2 INSTALLATION

Preferable choose an operating location that is dry and cool, and avoid operating the transceiver in direct sunlight. Allow adequate ventilation particularly during mobile operation.

2.3 CONNECTION

Connect the transceiver as illustrated in Fig. 1.

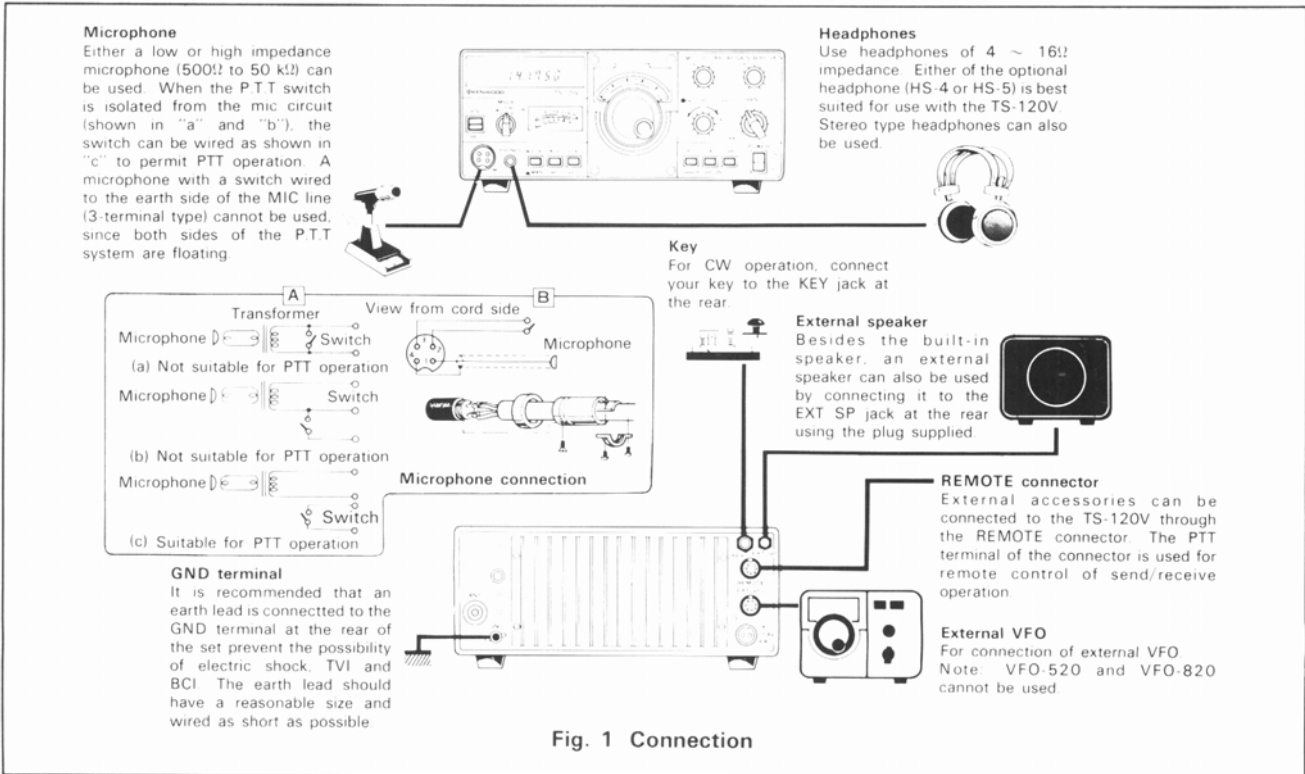

2.5 ANTENNA AND POWER SUPPLY

Connect the antenna and power supply appropriate to the purpose of use (fixed station or mobile station operation).

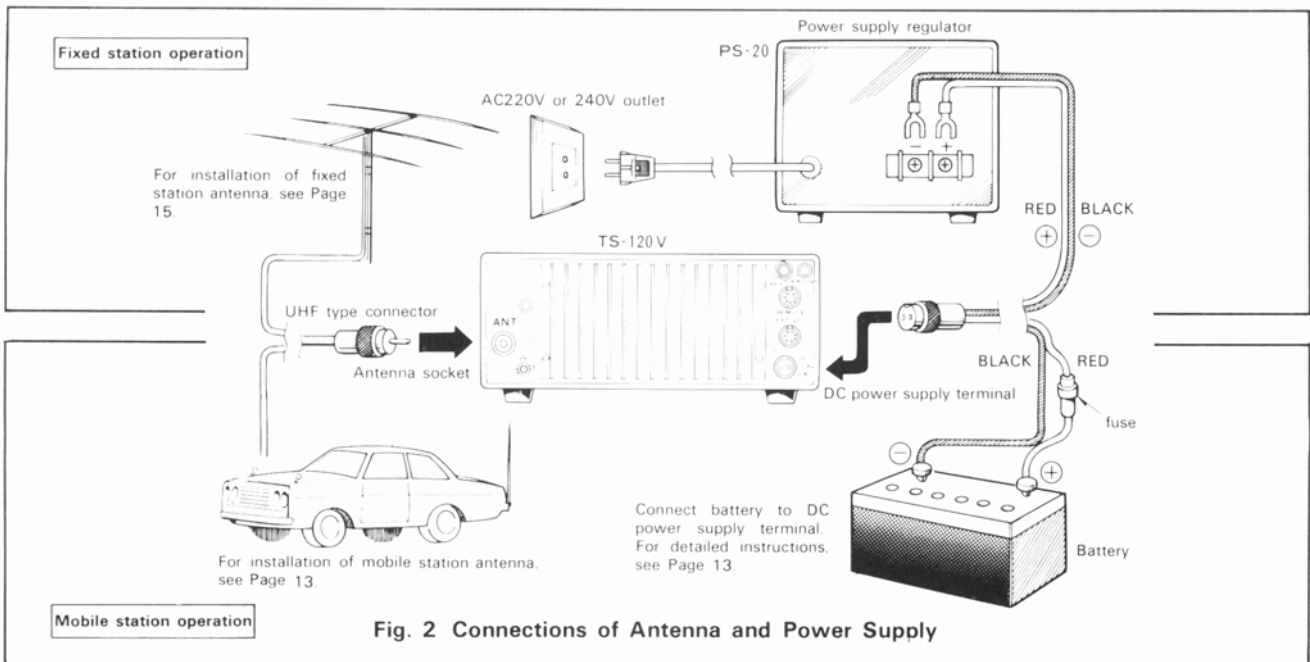

SECTION 3. CONTROLS

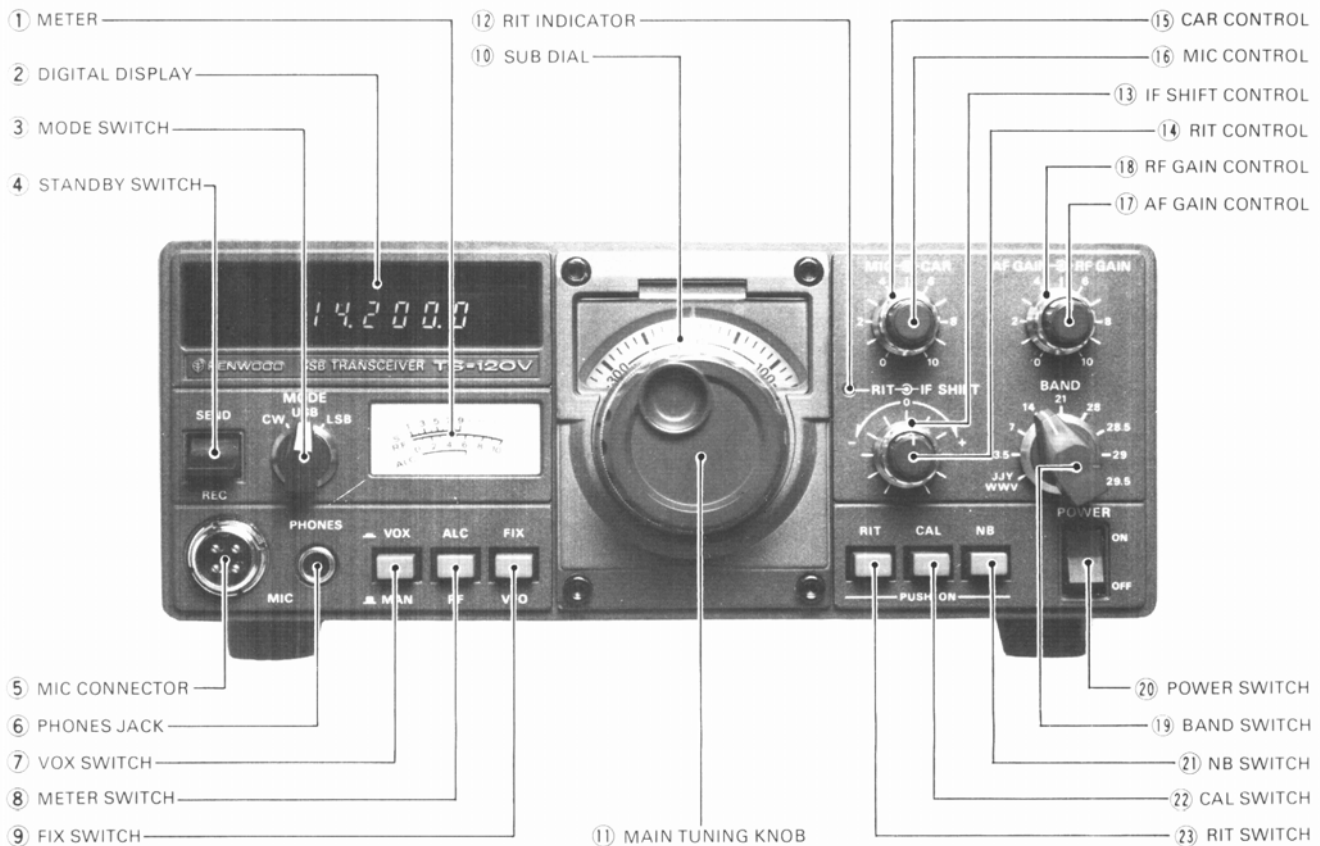

FRONT PANEL

3.1 FRONT PANEL

① METER

The meter has three functions, each being selected by the METER switch. In receive the meter is automatically an S-meter. The S-meter shows receive signal strength on a scale of 1 ~ 9, 9 + 20 dB, 9 + 40 dB and 9 + 60 dB. In transmit, the meter shows RF output or ALC level depending on the position of the METER switch.

② DIGITAL DISPLAY

The digital display unit indicates true operating frequency to an accuracy of 100 Hz.

③ MODE SWITCH

The mode switch is used for selection of type of operation.

LSB Used for LSB operation. It is internationally agreed that LSB is used in the 3.5 and 7 MHz bands.

USB Used for USB operation. It is internationally determined that the 14, 21 and 28 MHz bands belong to USB.

CW Used for CW operation.

④ STANDBY SWITCH

This switch is used to select the mode of operation, receive or transmit.

The transceiver is normally in the receive mode at the REC position unless the microphone PTT switch is pressed to ON. At the SEND position, the TS-120V is switched to the transmit mode. When using this facility, make certain that the antenna is properly connected, as improper connection (i.g. ANT terminal is open or shorted) will result in serious damage to the TS-120V.

⑤ MIC CONNECTOR

The microphone connector has four pins. Connect your microphone (MC-30S, MC-35S, MC-50, etc.) referring to Fig. 1. The TS-120V accepts both low and high impedance microphones.

⑥ PHONES JACK

The headphone jack allows use of a 4 to 16 ohms set of headphones. The optional headphones (HS-4, HS-5) provide optimum results. Stereo type headphones can also be used.

⑦ VOX (VOICE CONTROL) SWITCH

This switch is used for SSB VOX operation or CW semi-break-in operation. In the MAN position, the transceiver is switched to transmit or receive by the standby switch or the PTT switch on the microphone. In the VOX position, the VOX circuit is activated to permit VOX operation or semi-break-in operations (see Page 11).

⑧ METER SWITCH

The meter switch determines the function of the meter. The switch selects one of the following functions:

ALC In this position the meter monitors the output of the final stage power amplifier during transmission. During SSB operation, adjust the MIC control so that the meter pointer is within the ALC zone. Similarly, adjust the CAR control for CW operation.

*AUT-LEVEL
CONTROL*

RF..... In this position the meter monitors the relative RF output of the transceiver.

⑨ FIX (fixed channel) SWITCH

The TS-120V has a built-in fixed channel oscillator (crystal elements are optional) which is activated by the FIX switch for fixed channel operation or VFO operation.

⑩ SUB-DIAL

The sub-dial is calibrated from 0 to 500. It is driven from the main tuning knob to indicate the operating frequency of the transceiver.

⑪ MAIN TUNING KNOB

This control is used to select the desired operating frequency. The scale on the control knob is calibrated at 1 kHz intervals, allowing accurate tuning.

⑫ RIT INDICATOR

This light emitting diode is illuminated to indicate that the RIT circuit is turned on.

⑬ IF SHIFT CONTROL

By using this control, the IF crystal filter center frequency can be shifted ± 1 kHz, allowing adjustment of tone quality or eliminating interference from adjacent frequencies. For normal operation, this control should be set to the center "0" position at which a click stop is provided.

⑭ RIT CONTROL

This is used to vary the receive frequency by about ± 1.5 kHz when the RIT circuit is ON. The RIT circuit is OFF when the control is set to the center "0" position.

⑮ CAR (CARRIER LEVEL) CONTROL

This control is used to adjust the output carrier level during CW operation. Adjust the control so that the ALC meter indicates within the ALC zone.

⑯ MIC (MIC GAIN) CONTROL

This control adjusts the gain of the mic amplifier during SSB operation. Adjust the control so that the ALC meter indicates within the ALC zone.

⑰ AF GAIN (AUDIO GAIN) CONTROL

This control adjusts the gain of the receiving audio amplifier. The audio volume of the received signal increases as the control is turned clockwise.

⑱ RF GAIN CONTROL

This control adjusts the gain of the receiver section's RF amplifier. Turn the knob fully clockwise for maximum gain. Turn it counterclockwise to reduce the gain.

⑲ BAND SWITCH

The 9-position switch selects all the amateur bands from 3.5 to 29.7 MHz and WWV. Set the switch to the desired operating band.

⑳ POWER SWITCH

This switch turns on and off the TS-120V.

㉑ NB (NOISE BLANKER) SWITCH

This switch is used to reduce pulsating ignition type noises usually emitted from motor vehicles.

㉒ CAL SWITCH

This switch turns ON and OFF the output of the built-in 25 kHz marker circuit. The output turns ON at the first press and turns OFF at the second.

㉓ RIT SWITCH

This pushbutton switch turns the RIT (Receiver Incremental Tuning) circuit on and off. With the switch depressed, the circuit is activated and the RIT indicator is illuminated, allowing the receive frequency to be shifted by about ± 1.5 kHz independently of the transmit frequency by using the RIT control. The RIT circuit is turned OFF when the switch is pressed once again.

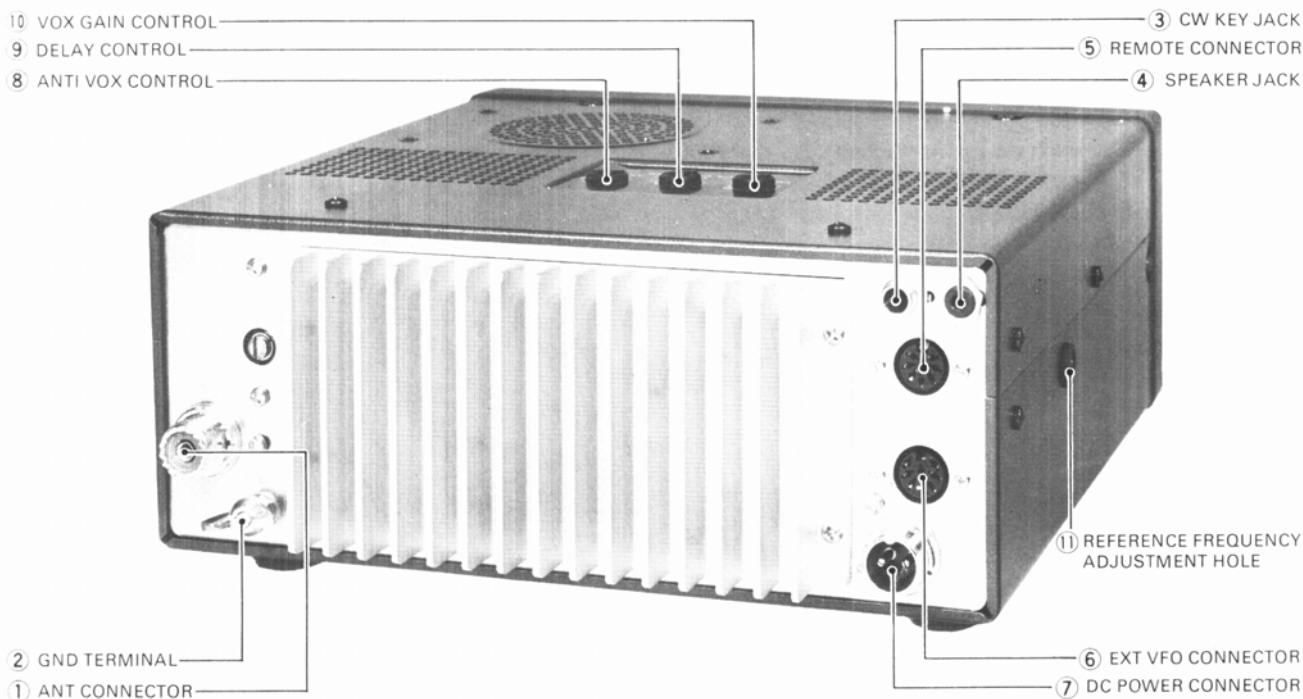

REAR PANEL

3.2 REAR PANEL

① ANT (ANTENNA) CONNECTOR

This UHF type connector should be attached to a suitable antenna for transmitting and receiving. The antenna cable should be of a 50-ohm unbalanced type.

② GND (EARTH) TERMINAL

The TS-120V should be earthed through this terminal to avoid possibility of TVI and BCI.

③ CW KEY JACK

For CW operation, connect your key to this terminal using a 2P plug.

④ SPEAKER (EXTERNAL SPEAKER) JACK

An external speaker of 4 ~ 16 ohms or SP-120 impedance can be connected.

⑤ REMOTE CONNECTOR

The remote connector is used for interconnecting a linear amplifier or another unit. For connection, refer to the illustration below.

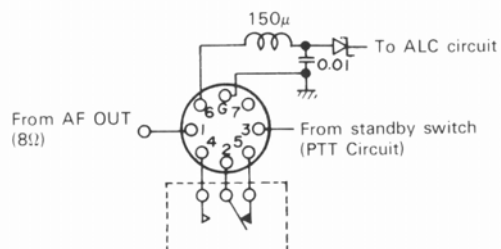

⑥ EXT VFO (EXTERNAL VFO) CONNECTOR

This connector is used for connection of an external VFO (VFO-120, etc.). VFO-520 and VFO-820 cannot be used, since their operating frequency is incorrect.

⑦ DC POWER CONNECTOR

This connector is used to connect the DC power supply.

⑧ ANTI VOX CONTROL

This control is used to adjust the VOX system so that it is not misoperated by the sound from the speaker.

⑨ DELAY CONTROL

This control is used to adjust the time constant of the VOX circuit. Adjust it for optimum VOX operation.

⑩ VOX GAIN CONTROL

This control adjusts the sensitivity of the VOX circuit to provide satisfactory VOX operation.

⑪ REFERENCE FREQUENCY ADJUSTMENT HOLE

For adjustment of reference oscillating frequency for PLL, counter and marker circuits. Use WWV signal for calibration.

SECTION 4. OPERATION

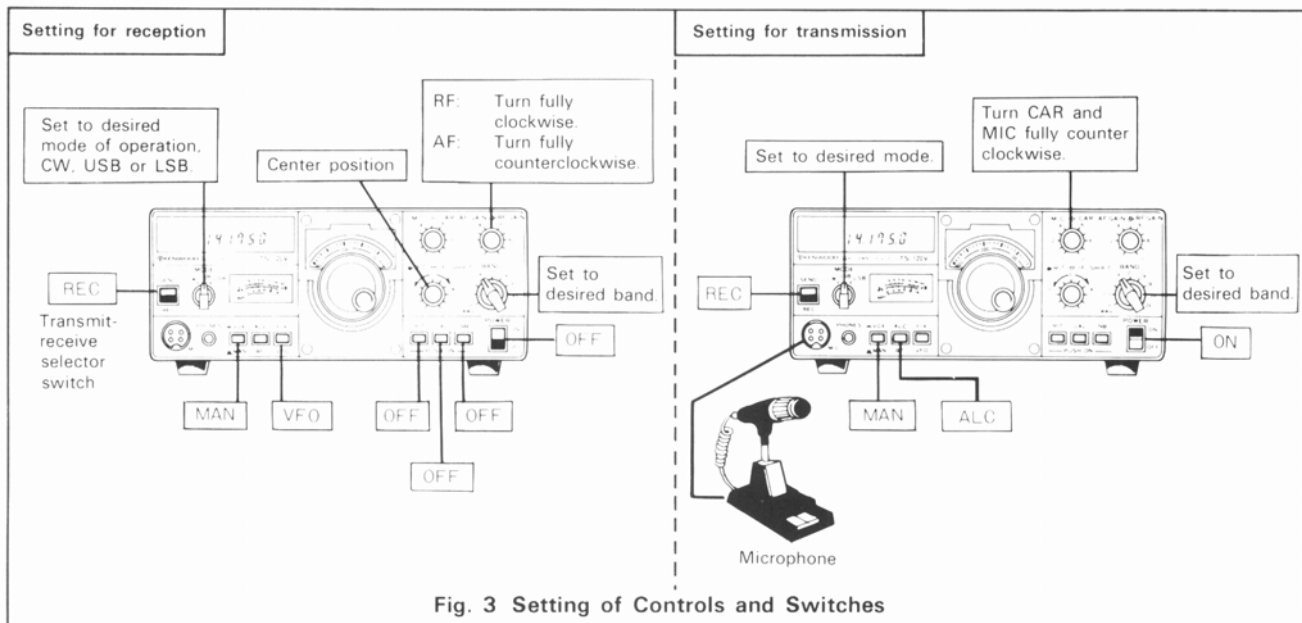

Fig. 3 Setting of Controls and Switches

4.1 RECEIVER TUNING

First connect the antenna, microphone and key. Then, set the controls and switches referring to Fig. 3. For SSB operation the MODE switch should be set to comply with the international rules, that is, it should be set to LSB to receive 3.5 and 7 MHz bands only, and to USB to receive the bands above 14 MHz.

Ascertain that the TS-120V is ready for operation, then turn the POWER switch to ON. The meter and dial scale will be illuminated, indicating that the transceiver is in operation. The receiver section is fully solid-state allowing reception as soon as the POWER switch is turned ON.

Advance the AF GAIN control clockwise until some receiver noise is heard in the speaker. Turn the main tuning knob so that your desired signal can be heard clearly.

While turning the main tuning knob, the frequency (MHz) reading on the digital display will change at the edge of each band, for example, from 28.999.9 to 29.000.0 MHz. In this case 1 MHz and 10 MHz digits are blanked.

| | | | | | |
|---------|---------|----------|----------|----------|----------|
| 3.999.9 | 7.000.0 | 14.000.0 | 21.000.0 | 28.000.0 | 29.999.9 |
| 000.0 | 999.9 | 999.9 | 999.9 | 999.9 | 000.0 |

4.1.1. RECEPTION OF WWV

To receive WWV (15 MHz) signals, set the BAND switch to JY/WWV and turn the main tuning knob, then set the subdial to "500". The digital display indicates ".000.0" instead of 15.000.0.

4.1.2 NB SWITCH

The TS-120V has a sophisticated noise blanker designed to reduce ignition type impulse noise. The noise blanker is particularly important for mobile operation. When necessary, activate the noise blanker circuit by turning the NB switch to ON.

4.1.3 RF GAIN CONTROL

For normal operation, this knob should be turned fully clockwise for maximum sensitivity. The receive sensitivity is reduced by turning the control counterclockwise. Adjust the RF GAIN so that the S-meter does not cause excessive deflection. This minimizes the noise during reception and allows the S-meter to indicate the correct signal strength. By adjusting the RF GAIN so that the S-meter indicates the peak point or a little below that point, the noise is markedly reduced when the signal is absent.

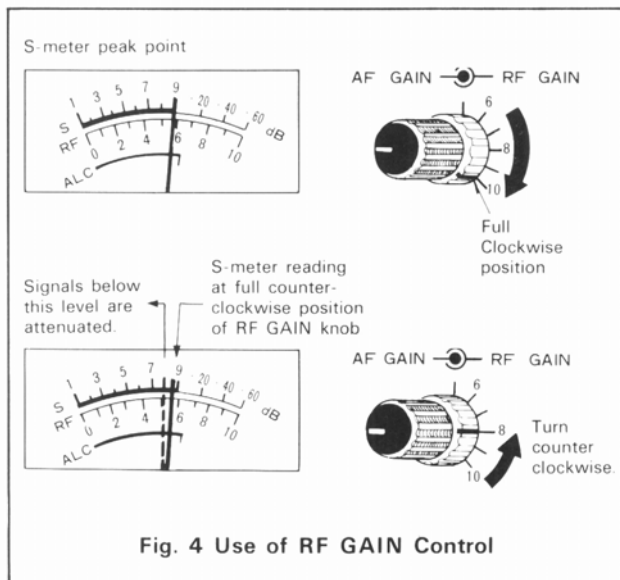

Fig. 4 Use of RF GAIN Control

4.1.4 RIT CONTROL

By using the RIT (Receiver Incremental Tuning) control, the receive frequency can be shifted by about 1.5 kHz without changing the transmit frequency.

If the frequency of the station you are working changes, your receive frequency can be set to the station by turning the RIT switch to ON and adjusting the RIT control. Turning the control clockwise increases the frequency, and vice versa. The RIT shift can be checked by the digital display. When calling another station, the RIT switch must be set to OFF, because otherwise the transmit frequency will not coincide with the receive frequency.

4.1.5 IF SHIFT CONTROL

The IF SHIFT control is used to shift the passband-width of IF filter without changing the receive frequency. By turning this knob in either direction, the IF passband-width is shifted as shown in Fig. 5.

The use of the IF SHIFT knob is effective in eliminating interference when the receive signal is superposed on nearby signals during operation in USB, LSB or CW mode.

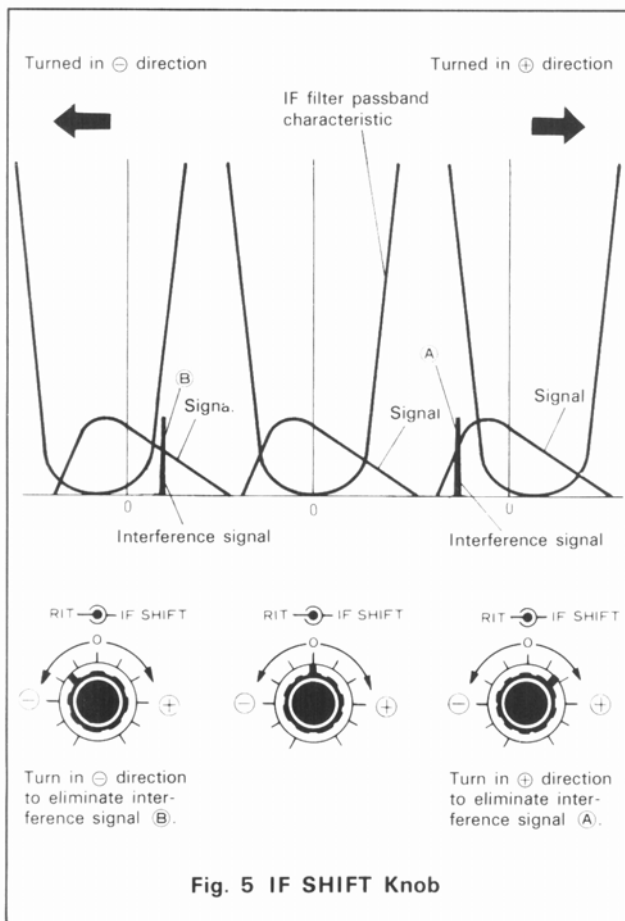

(1) USB Mode

Turn the IF SHIFT control in the ⊕ direction and the lower frequencies are cut out. Turning the control in the ⊖ direction cuts out the higher frequencies.

(2) LSB Mode

Turn the control in the ⊕ direction and the higher frequencies are cut out. Turning the control in the ⊖ direction cuts out the lower frequencies.

(3) CW Mode

By using the IF SHIFT control in conjunction with the RIT control, the tonal quality can be adjusted.

4.2 TRANSMITTER TUNING

NOTE:

In transmitting, be sure to connect an antenna with VSWR of less than 1 : 1.5 or an appropriate dummy load. Never attempt to transmit with the antenna terminal left open.

When testing the transmitter, connect a 50-ohm dummy load (RD-15).

The dummy load used should be rated at more than 10W. Refer to Fig. 3 for the initial settings of controls and switches.

When the TS-120V is ready for transmission, use the following procedure:

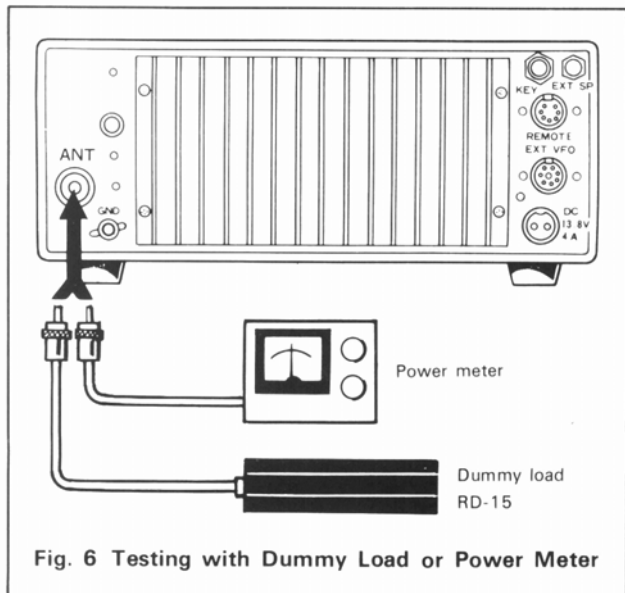

● **SSB Operation**

- ① Set the Mode switch to LSB or USB.
- ② Set the meter switch to ALC.
- ③ Set the standby switch to SEND.
- ④ Speak into the microphone and adjust the MIC GAIN control so that the meter pointer deflects within the ALC zone at peak signals.

● **CW Operation**

- ① Set the MODE switch to CW and the meter switch to ALC.
- ② Set the standby switch to SEND and adjust the CAR control so that the meter pointer is within the ALC zone. This adjustment should be made with the KEY jack left open. If a key is connected, it should be depressed during the adjustment.

4.2.1 PROTECTIVE CIRCUIT

The TS-120V has a built-in protective circuit for protection of the final stage transistors.

If the antenna VSWR becomes high due to improper impedance, the protective circuit is activated to prevent the final stage from being overloaded.

When the circuit is activated (this reduces the transmit output), check the antenna impedance and take necessary steps to correct it.

4.2.2 MIC GAIN CONTROL

This control adjusts the microphone input level. When using the TS-120V in USB or LSB mode, connect the microphone and set the standby switch to SEND (antenna or dummy load must be connected).

Set the meter switch to ALC and speak into the microphone. Adjust the MIC GAIN control so that the meter pointer does not deflect out of the ALC zone at peak signals.

The TS-120V accepts either low or high impedance microphone (500Ω to 50kΩ). When using a low impedance microphone (500Ω) the MIC GAIN control should be advanced higher than when a high impedance microphone is used, while observing the ALC meter.

● **ALC (Automatic Level Control)**

The ALC monitors the transmitter final stage output to minimize distortion in the signal. It automatically adjusts the output to optimum level.

4.3 VOX OPERATION

4.3.1 VOX SWITCH

The VOX (voice control) switch is used to switch the TS-120V in transmit or receive mode by voice signals. Set the switch to ON and speak into the microphone. The transceiver automatically operates in transmit mode (the MIC control should be adjusted in advance as explained in Item 4.2.2).

4.3.2 VOX GAIN CONTROL

This control adjusts the sensitivity of the VOX circuit. Speak into the microphone at normal voice levels and turn the control. A clockwise turn increases the sensitivity, allowing transmission with low level of voice. The operating condition of the transceiver can be checked by the sound from the speaker. When the speaker is silent, it means that the transceiver is operating in transmit mode.

Note that if the control is advanced too far, the VOX circuit is misoperated by noise from the microphone.

4.3.3 ANTI VOX CONTROL

This control is used to prevent the VOX circuit from being misoperated by the sound from the speaker.

Adjust the control so that the VOX circuit will not operate at the preset volume level.

4.3.4 VOX DELAY CONTROL

This control adjusts the transmit-hold-time of the VOX circuit. If the hold time is too short, the transceiver will operate in receive mode as soon as you stop talking into the microphone. This can be eliminated by turning the control clockwise. Adjust the control so that optimum VOX operation is effected at normal speed of talking.

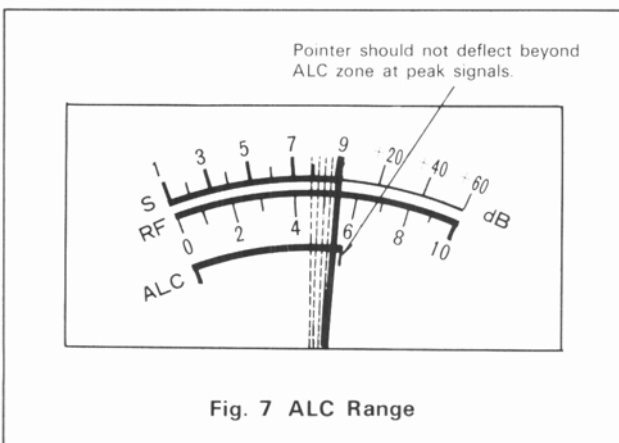

Fig. 7 ALC Range

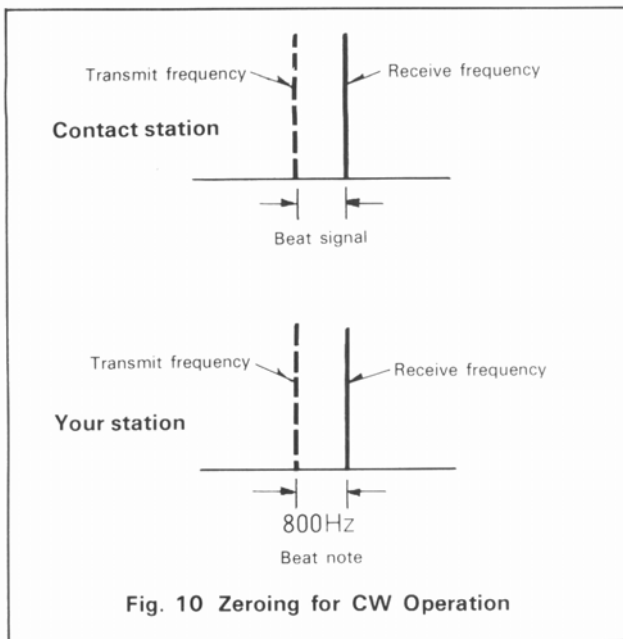

Fig. 10 Zeroing for CW Operation

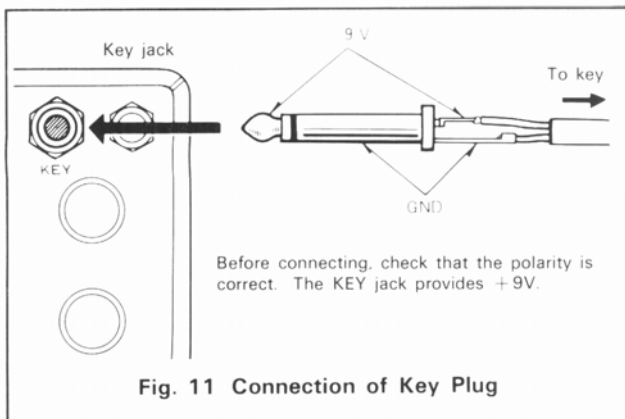

Fig. 11 Connection of Key Plug

4.6.1 OPERATION WITHOUT CW FILTER

Set the IF SHIFT control to its center position and the RIT switch to the OFF position to receive CW signal. Turn the main tuning knob to give on 800 Hz beat note and your transmit frequency will then be set to the transmit frequency of the contact station (zeroing). During reception, the side tone monitor is activated by pressing down the key. In this case, listen to the side tone signal and the receive signal and adjust the main tuning knob so that the cycle of the sound is increased. By so doing, the zeroing of the frequency is achieved.

After zeroing, set the RIT switch to ON and turn the RIT knob for the pitch that suits your listening taste. When interference is encountered, turn the IF SHIFT control and the interference can be eliminated. For more effective CW operation, use of the CW crystal filter YK-88C (option) is recommended.

4.6.2 OPERATION WITH CW FILTER (YK-88C)

Set the IF SHIFT knob to its center position and the RIT switch to OFF to receive CW signal. Adjust the main tuning knob for maximum deflection of the S-meter. The pitch of the sound of the receive signal will now be about 800 Hz, indicating that the zeroing is correct.

4.6.3 CONNECTION OF KEY

Your key should be connected as illustrated in Fig. 11, making sure that the polarity is correct.

4.7 MOBILE OPERATION

The TS-120V is compact in design and is ideal for mobile operation. Satisfactory mobile operation is achieved when the battery power and the antenna are properly connected and the TS-120V is properly installed and adjusted.

4.8.1 INSTALLATION OF TS-120V

Secure the TS-120V under the dashboard using the mounting bracket MB-100 (option) as shown in Fig. 12. As an alternative, use a proper mounting fixture or belt making sure that the TS-120V will not slip out of place while driving the vehicle.

NOTE:

1. Do not install the TS-120V near the outlet of the heater or cooler.
2. Allow sufficient space behind the TS-120V to ensure proper ventilation.

4.8.2 BATTERY CONNECTION

The TS-120V operates on DC 13.8V. It is advisable to connect the transceiver directly to the battery terminal using the DC power cord supplied. When connecting, check that the battery polarity is absolutely correct. The power cord is color coded; the **red** lead should be connected to the ⊕ side and the **black** one to the ⊖ side.

Ascertain that the power cord is not too close to the high tension cord wired to the engine ignition plug.

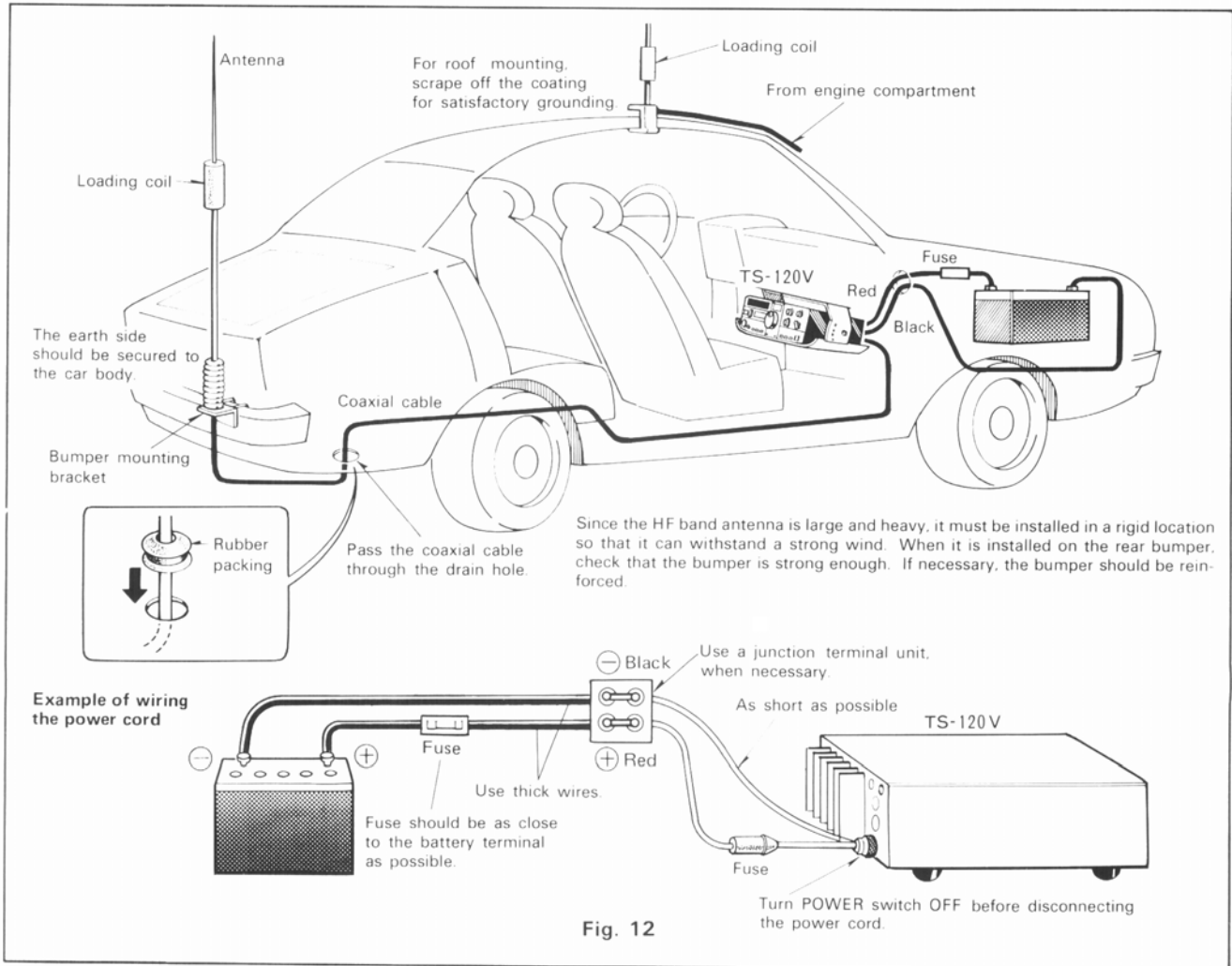

Fig. 12

4.7.3 ANTENNA INSTALLATION

(1) Types of Antenna

HF band antennas for mobile operation are also available from many manufacturers.

Select a suitable type of antenna according to the operating band, size of vehicle and installation location. Unlike fixed station antennas, mobile station antennas are small in size and inferior to the former in terms of performance.

(2) Installation

An HF antenna for mobile operation is larger and heavier than a VHF antenna and must be installed on a rigid location. Antennas for use in 3.5 or 7 MHz band or all-band antennas can be installed on the bumper of vehicle as shown in Fig.12. Loading type or helical type antennas for use in 21 or 28 MHz band can be installed on the roof as in VHF type antennas.

(3) Connection of Coaxial Cable (Fig. 12)

When the antenna is mounted on the bumper of vehicle, the

coaxial cable can be connected to the antenna through any drain hole provided in the trunk. When the antenna is mounted on the roof, connect the cable through the hole in the door. In this case, care should be used not to allow rain water to come into the vehicle.

(4) Antenna Adjustment

Some mobile antennas are not designed for 50-ohm impedance. In this case, impedance matching between the antenna and the coaxial cable (50Ω) is required. This can be achieved by using a matching box or antenna coupler.

The antenna to be used should first be checked with a dip meter to insure that it is designed for your operating band, then the impedance matching be checked using an SWR meter. (See Fig. 13)

The VSWR should preferably be less than 1 : 1.5 for satisfactory operation. For adjustment of the antenna, refer to the instruction manual for the antenna.

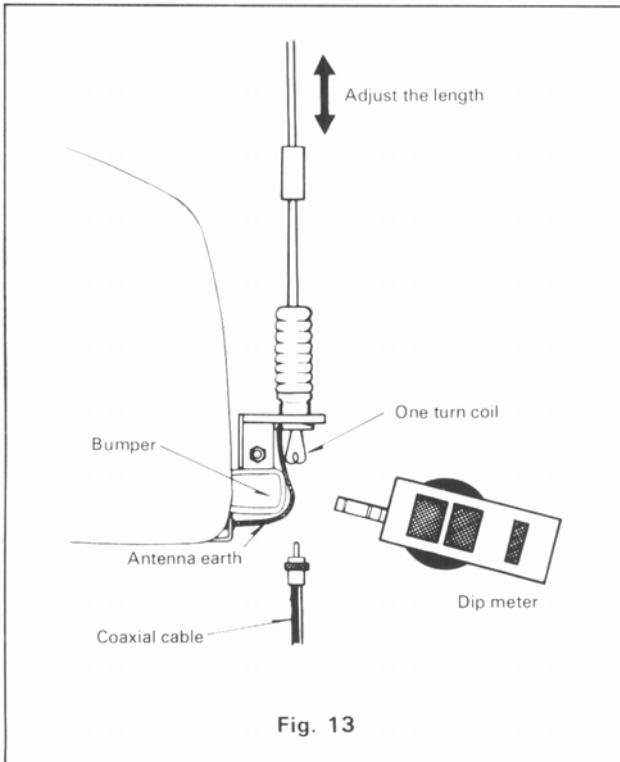

4.7.4 NOISE REDUCTION

In motor vehicles, ignition noise is generated by the ignition coil or distributor and other sources the wiper motor or heater motor.

Although the TS-120V is equipped with a noise blander to minimize ignition noise, it is imperative that some preventive measures be taken to reduce the noise to the lowest possible level. To reduce noise, proceed as follows:

(1) Selection of Antenna Installation Location

Since ignition noise is generated by the vehicle engine, the antenna must be installed as far away as possible from the engine.

(2) Use of Ignition plug with internal Resistor

Noise can be reduced by using an ignition plug with internal resistor. Use of resistive ignition cable is also effective.

(3) Bonding

The component parts of motor vehicles, such as the engine, transmission, silencer, accelerator, etc., are coupled to one another at DC and low frequencies, but are isolated at high frequencies. By connecting these parts using shield braid of coaxial cables, ignition noise can be reduced. This connection is called "bonding".

(4) Battery Power Connection

It is recommended that battery power be supplied to the TS-120V directly from the battery terminal and the \ominus side be earthed at a point near to the TS-120V where the noise is at a minimum.

(5) Antenna Matching

In general, mobile antennas have a lower impedance than 50-ohm coaxial cables, resulting in mismatching between the antenna and the coaxial cable. Such a trouble can be eliminated by connecting an antenna tuner between the TS-120V and the coaxial cable.

○ Example of Matching Circuit

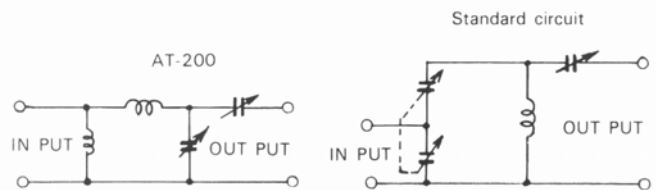

(6) Battery Capacity

The power supply system of motor vehicle comprises a battery and an alternator (generates power while the engine is running) to supply current to loads or to charge the battery.

Since the transceiver draws much current, care should be used so that the alternator is not overloaded when operating it.

When using the transceiver, the following points should be observed from the viewpoint of battery maintenance:

- ① Turn the transceiver OFF when the lights, heater, wipers and other electric apparatuses are in use.
- ② Avoid using the transceiver for a long time when the engine is not running.
- ③ If necessary, use a ammeter and/or a voltmeter so that the battery power can be checked.

4.8 FIXED STATION OPERATION

4.8.1 POWER SUPPLY

The TS-120V is designed to operate on 13.8 VDC. It draws a current of 4A (max.) during transmission. For operation, connect a suitable type of DC power regulator. The PS-20 DC power regulator is available as an optional accessory. It perfectly matches the design and performance of your TS-120V.

4.8.2 ANTENNA

For HF band fixed station operation, it is recommended that an antenna specifically designed for amateur band operation be used. This type of antenna is available in various kinds, such as the wire antenna, vertical antenna and rotary beam antenna. Select a suitable type of antenna that matches the operating conditions. Antennas for use in HF band are quite large in size and must be installed rigidly to withstand strong wind or heavy rain.

Any antenna used with the TS-120V should be of 50-ohm impedance and should be connected using an appropriate coaxial cable such as RG-8/U.

In connecting, impedance matching is important. Improper impedance matching will result in increase in VSWR and power loss, or will possibly cause unwanted radiation and interference (TVI, BCI).

The impedance matching can be checked by using an SWR meter. In general, satisfactory operation is assured when the VSWR is less than 1 : 1.5.

NOTE:

VSWR: Voltage Standing Wave Ratio.

For impedance matching between the antenna system and the transceiver, use of the Antenna Tuner AT-200 (option) is recommended.

The rotary beam antenna is very effective for DX operation in 14, 21 and 28 MHz bands.

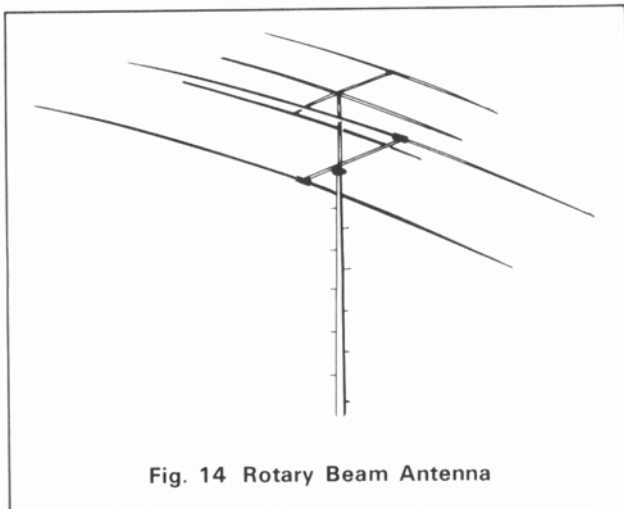

4.9 CALIBRATION OF COUNTER REFERENCE FREQUENCY

Connect the antenna and set the BAND switch to WWV. Turn the main tuning dial to about "500" to receive 15 MHz WWV signal. Adjust the dial until a low frequency beat signal (beat of standard frequency and BFO) is heard. Next, depress the CAL switch and a marker signal is superposed on the WWV beat signal. A double beat (two beat signals of high and low frequencies) will now be heard.

While receiving the double beat, adjust the trimmer of the counter unit through the reference frequency adjusting hole provided at the side of the TS-120V so that the two beat signals are heard as a single beat. This completes the calibration of the digital display. After the calibration, press and release the CAL switch. If required, adjust the antenna side until the WWV signal level becomes almost equal to the level of the marker signal.

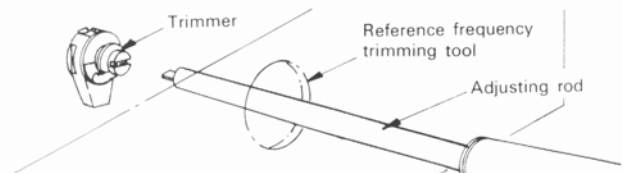

4.10 CALIBRATION OF MAIN DIAL SCALE

The main dial scale is graduated at 1 kHz intervals. One revolution of the main dial knob represents 25 kHz. To calibrate the scale, set the CAL switch to ON and align the marker signal with a 5 kHz interval (long line). When calibrated, a zero beat is heard in SSB mode and 800 Hz beat in CW mode.

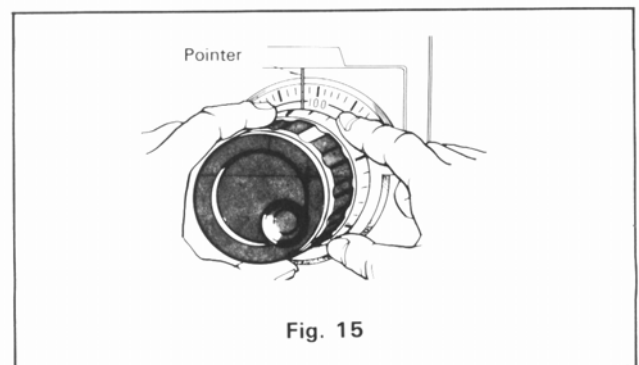

TROUBLESHOOTING

If trouble arises with the unit, conduct the following checks. Quite often, transceivers fail to operate correctly because of improper connections of cables and incorrect settings of controls and switches.

| Trouble | Cause | Remedy |
|--|---|--|
| Unit completely dead with Power switch ON. | <ol style="list-style-type: none"> 1. Power cord disconnected or AC power OFF. 2. Loose connection of power connector. 3. Blown fuse. | <ol style="list-style-type: none"> 1. Connect power cord. Turn AC power ON. 2. Connect firmly. 3. Replace fuse (If new fuse blows again, contact service station). |
| No signals received with antenna connected. | Microphone PTT switch is in transmit position. | Set PTT switch to receive position. |
| No signals received, and S-meter is deflected up scale with antenna connected. | RF gain reduced. | Turn RF GAIN control fully clockwise. |
| S-meter deflects without signals. | <ol style="list-style-type: none"> 1. Power voltage is too low. 2. RF circuit gain is too low. | <ol style="list-style-type: none"> 1. Adjust voltage to 13.8V (12 ~ 16V). Reset voltage selector to correct local AC line voltage with use of PS-20. 2. Turn RF GAIN knob fully clockwise. |
| No SSB reception. Wrong sideband. | Set MODE switch to alternate SSB position. Frequency remains the same when RIT control is adjusted. | RIT switch is OFF. Set RIT switch ON. |
| Frequencies (MHz order) not indicated on digital display. | This is normal; the digital display will not indicate frequencies (MHz order) in the following bands: 3.5 MHz band 4.0 and higher 7.0 MHz band 7.0 and lower 14.0 MHz band 14.0 and lower 21.0 MHz band 21.0 and lower 28.0 MHz band 28.0 and lower 29.0 MHz band 30.0 and higher | Digital display is not defective. |
| No output. | Standby switch not in transmit position. CAR or MIC control in minimum position. | Turn CAR or MIC clockwise. |
| No SSB output. | <ol style="list-style-type: none"> 1. MIC jack or MIC plug loosely connected. 2. MIC control in minimum position. | <ol style="list-style-type: none"> 1. Connect firmly. 2. Turn MIC control clockwise. |
| VOX circuit inoperative. | <ol style="list-style-type: none"> 1. VOX control in minimum position. 2. VOX switch in MAN position. | <ol style="list-style-type: none"> 1. Turn VOX control clockwise. 2. Set VOX switch to VOX. |
| VOX operates with sound from speaker. | Incorrect setting of ANTI VOX knob. | Turn ANTI VOX control clockwise. |

SECTION 5. ACCESSORIES (OPTION)

The following accessories are available optionally for use with the TS-120V:

■ MICROPHONE MC-30S, MC-35S

Dynamic microphone with PTT switch specifically designed for mobile operation.

Impedance: 50k Ω (MC-30S)
500 Ω (MC-35S)

■ REMOTE VFO VFO-120

Perfectly matches the design and characteristics of the TS-120V. When this high performance and solid state VFO is used, "dual operation" can be performed, resulting in improvement of the TS-120V performance.

■ SPEAKER SP-120

Specially designed for TS-120V. Provides good volume of sound.

■ MICROPHONE MC-50

Uni-directional dynamic microphone with "locked" PTT switch provides excellent performance for VOX operation or when used in noisy location.

Impedance: 50k Ω and 600 Ω (switchable)

■ DE-LUXE HEADPHONE HS-5

Open-back type headphone designed for excellent tonal quality and comfortable fit. The air type ear pads can be readily replaced with the pressure type ones.

■ HEADPHONE HS-4

High performance dynamic type headphone with specially designed ear pads for fatigueless listening.

Impedance: 8 Ω

■ DC POWER REGULATOR (FIXED STATION) PS-20

Perfectly matches the design and characteristics of the TS-120V. Equipped with a protective circuit to protect the transceiver against damage due to shorts in the output terminals or overload.

■ HAM-CLOCK HC-2

24-hour type clock with pre-fix dial for easy reading of time in most of countries in the world. It keeps operating more than one year with a single dry battery.

■ CW CRYSTAL FILTER YK-88C

High selectivity (500 Hz at -6 dB, 1.5 kHz at -60 dB) crystal filter for CW operation. Readily used with the TS-120V.

PS-20

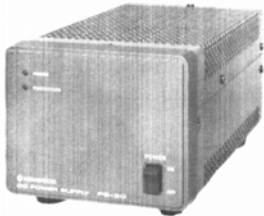

VFO-120



SP-120



MC-50



HC-2

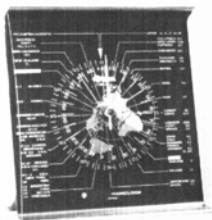

MC-30S, 35S



HS-4



HS-5



BLOCK DIAGRAM

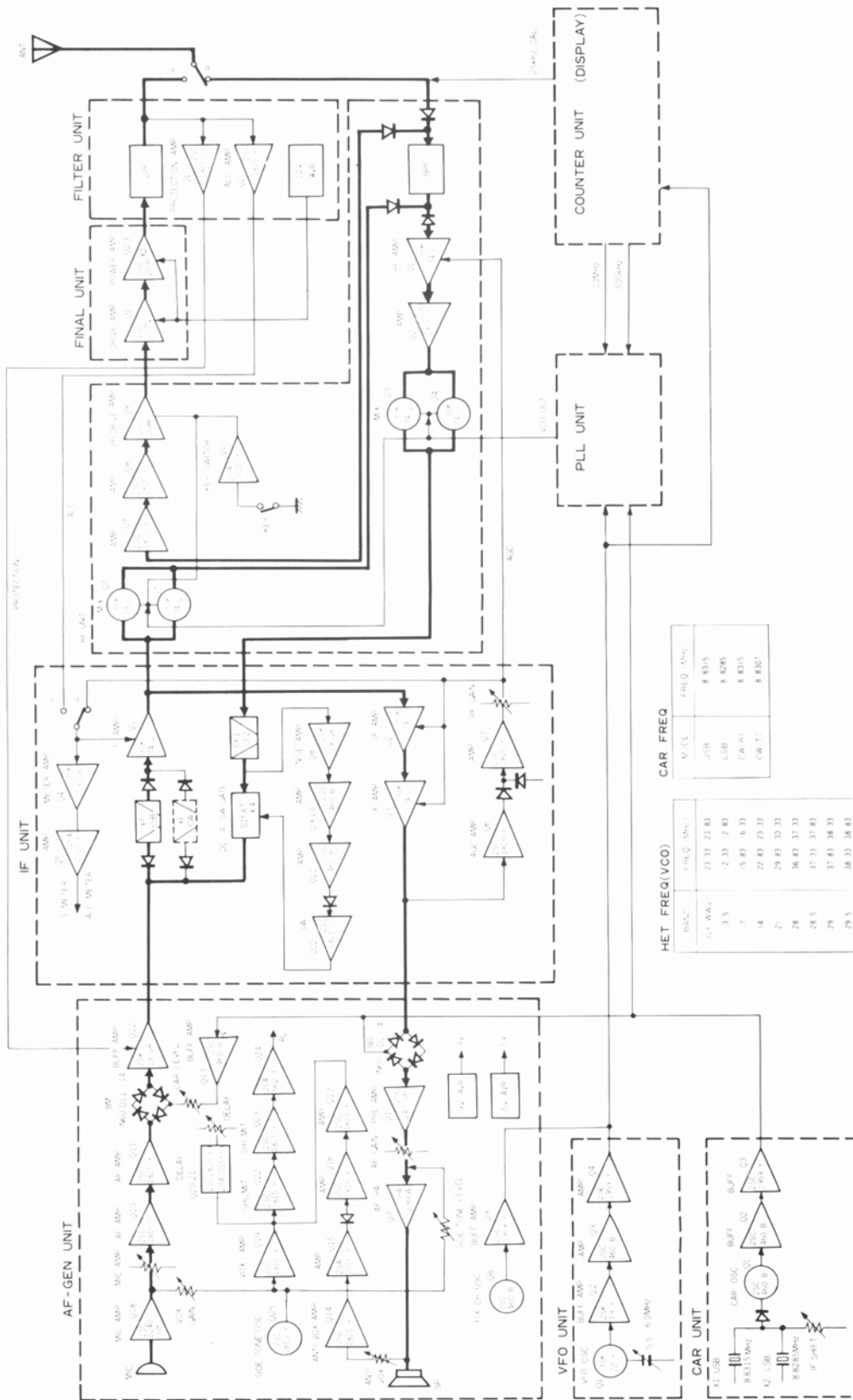

| MODE | FREQ. MHz |
|--------|-----------|
| USB | 8.835 |
| LSB | 8.8285 |
| FM (1) | 8.835 |
| FM (2) | 8.8307 |

| MODE | FREQ. MHz |
|--------|-------------|
| 1.5 AM | 23.33 23.83 |
| 3.5 | 12.33 12.83 |
| 7 | 15.83 16.33 |
| 14 | 22.83 23.33 |
| 21 | 29.83 30.33 |
| 28 | 36.83 37.33 |
| 28.5 | 37.33 37.83 |
| 29 | 37.83 38.33 |
| 29.5 | 38.33 38.83 |

Downloaded by

 Amateur Radio Directory

SCHEMATIC DIAGRAM

PLL UNIT (X50-1490-00)

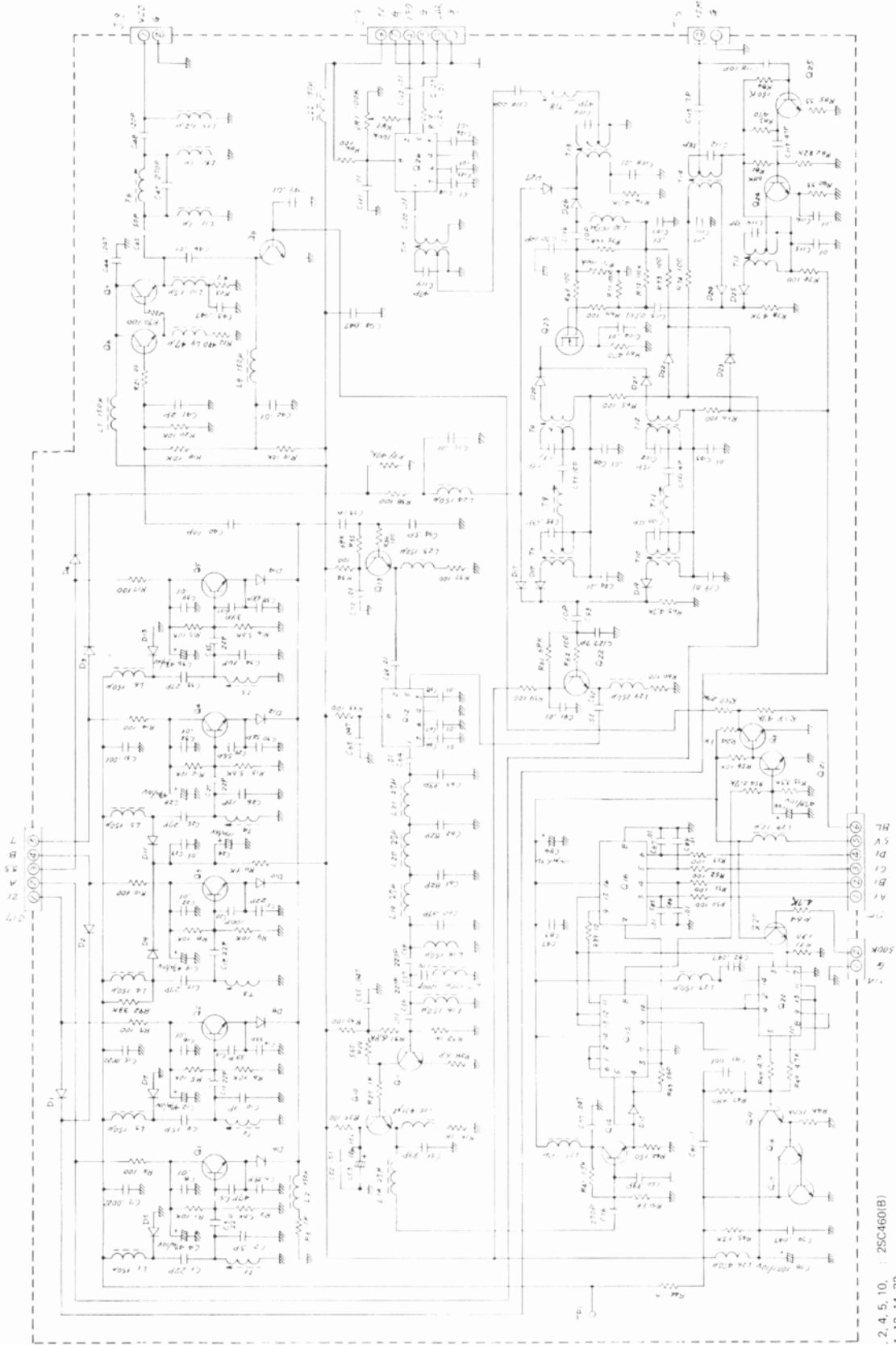

- | | | | | | |
|---|--------------|-------------------------|-------------|---|----------|
| 01, 2, 4, 5, 10, 11, 13, 14, 22, 24, 25 | : 25C460(B) | D1, 2, 3, 4, 15, 22, 23 | : 1S1555 | D6, 8, 12, 14, 17, 18, 19, 20, 21, 24, 25, 26, 27 | : 1S1587 |
| 07, 8 | : 25C1959(Y) | Q12, 26 | : SN16913P | D5, 7, 9, 11, 13, 24, 25, 26, 27 | : 1S2588 |
| 09, 21, 27 | : 25C1815(Y) | Q15 | : HD74LS00P | | |
| Q17, 18, 19 | : 25C1775(E) | Q16 | : 74LS163N | | |
| Q23 | : 3SK40(L) | Q20 | : MC4044P | | |
| Q3, 6 | : 25C784(I) | | | | |

Downloaded by
 Amateur Radio Directory

RF UNIT (X44-1260-00)

01, 3, 4, 5, 6 : 3SK74(L) Q9 : 25C2086
 02, 7, 8 : 25C1815(Y) Q10 : 25A1015(Y)
 D1, 3, 5 : 1S1587
 D2, 4 : 1S2888
 D6, 7 : 1S1555

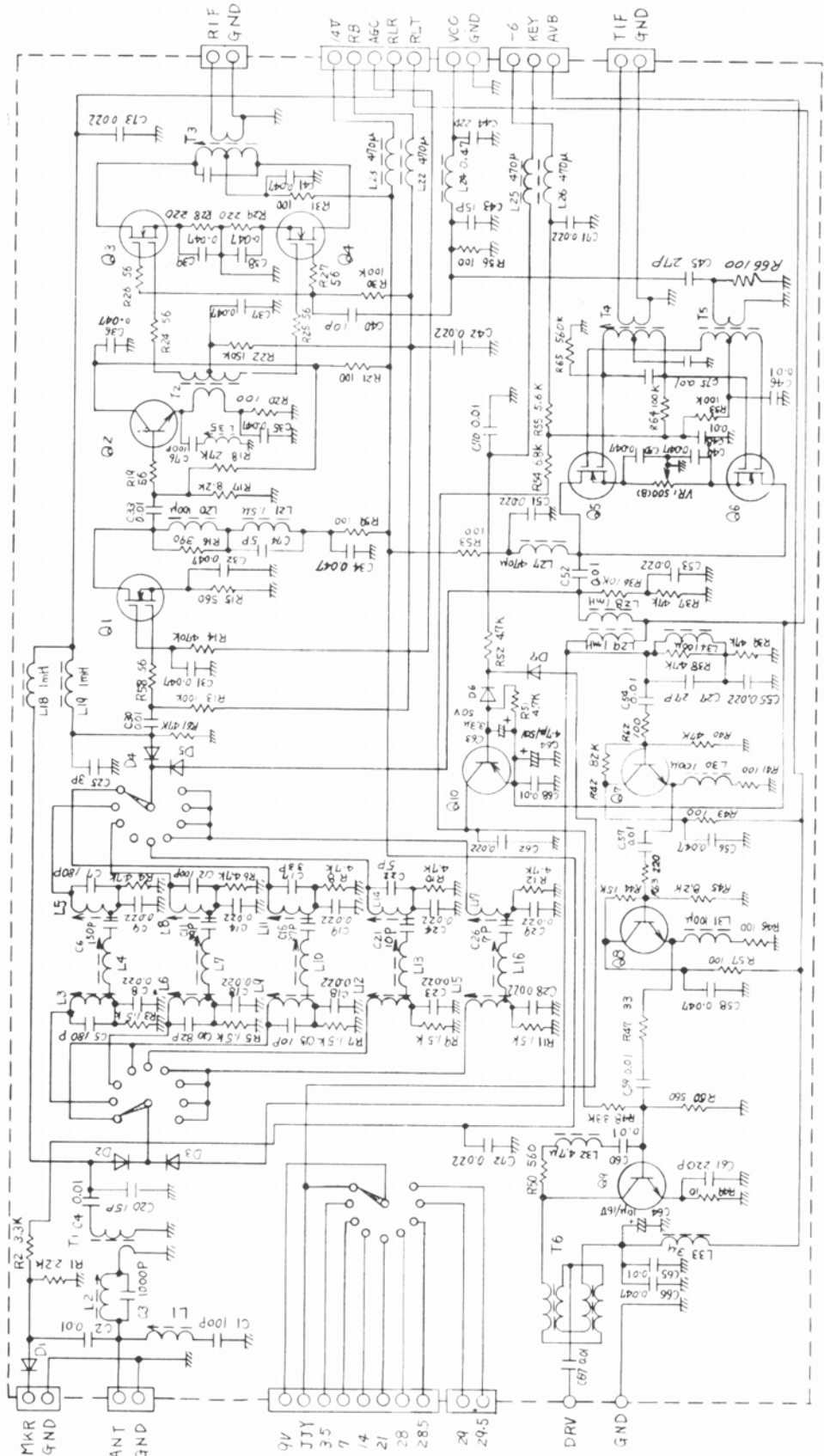

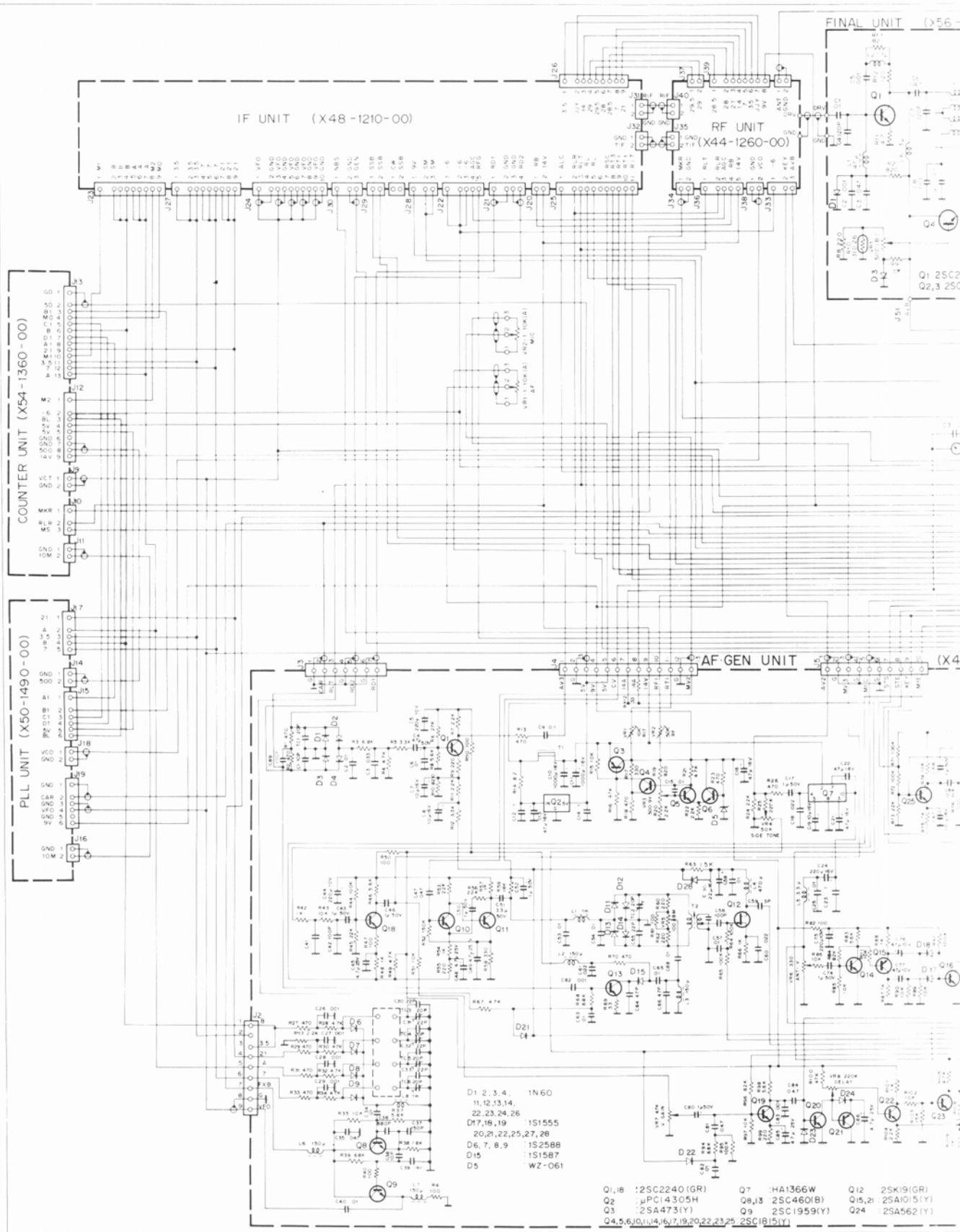

The circuit and ratings may change without notice due to development in technology.

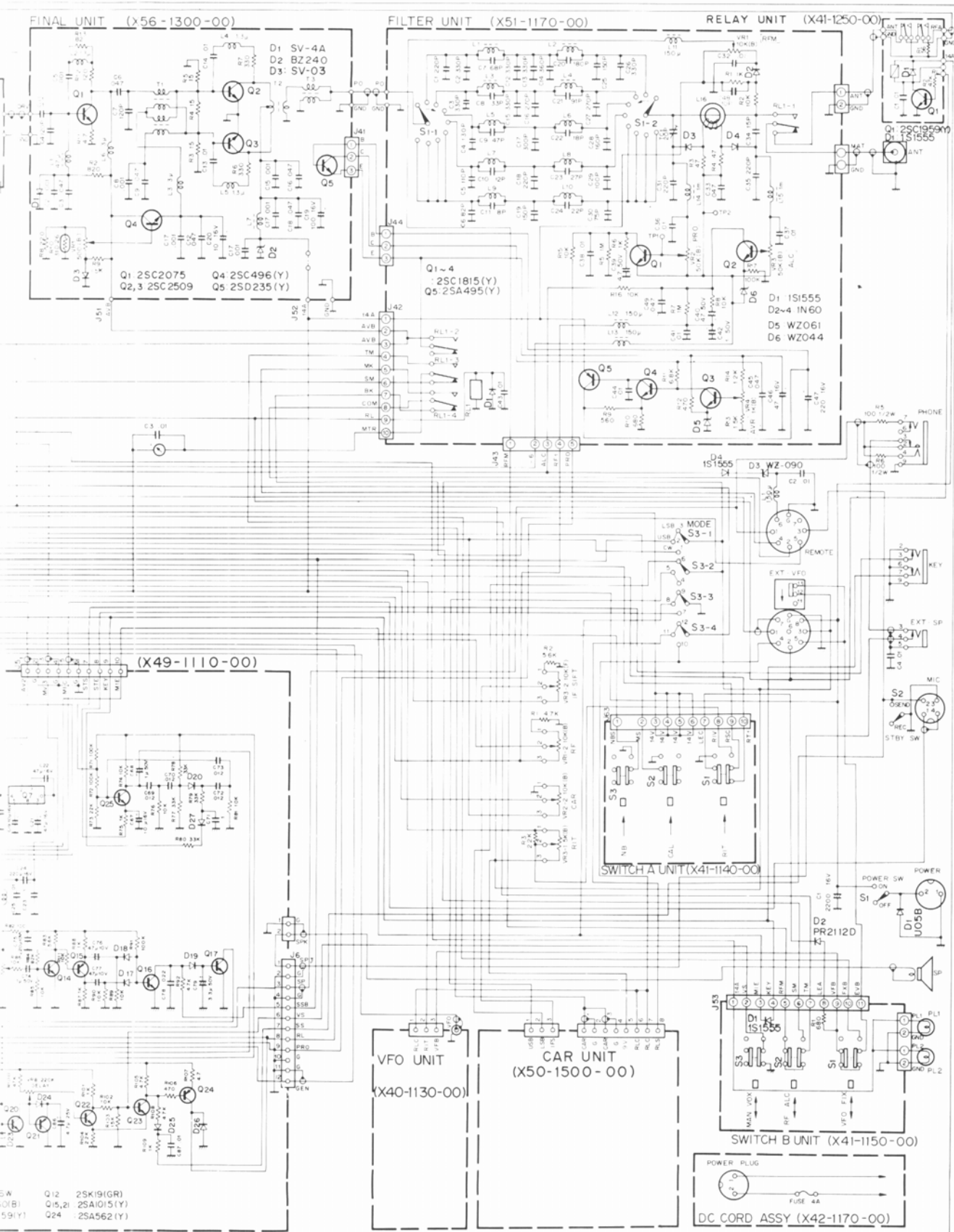

PARTS LAYOUT

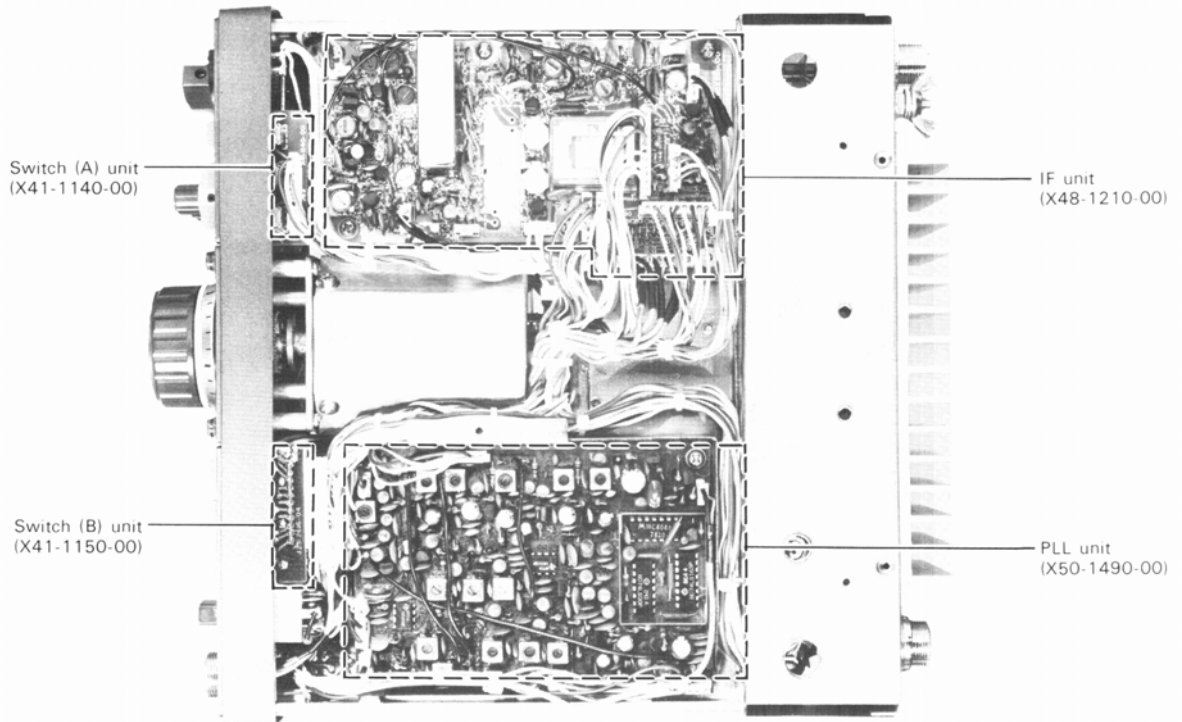
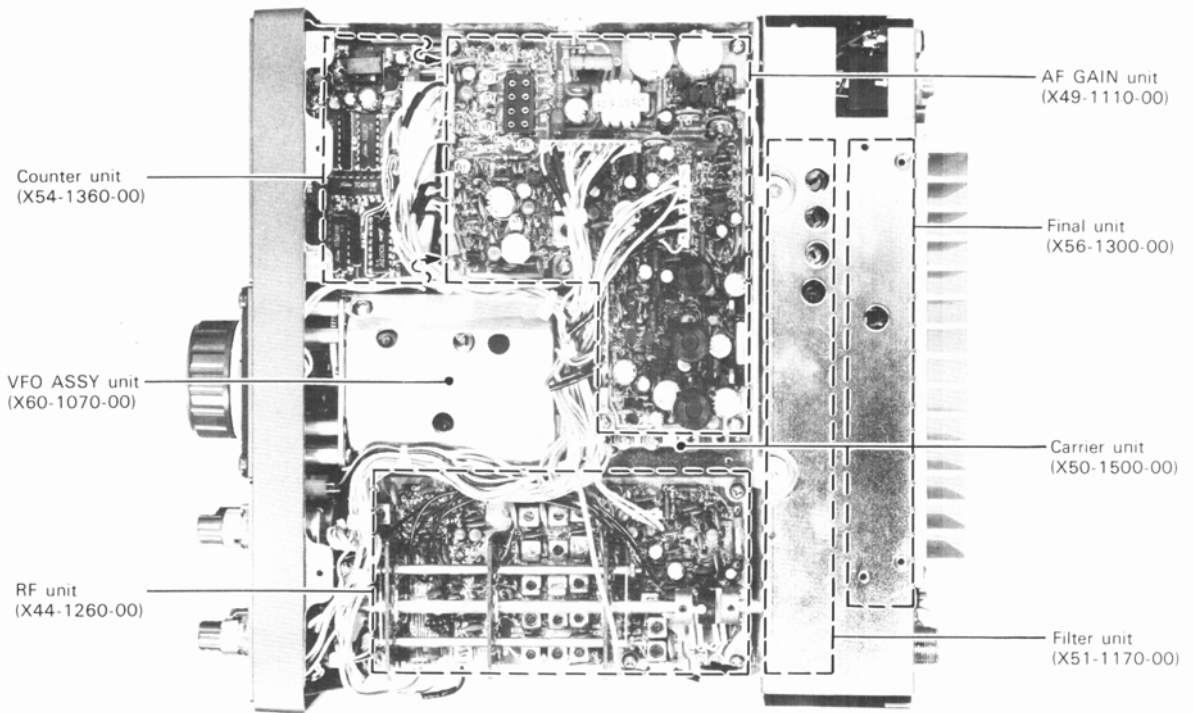

CAR UNIT (X50-1500-00)

- Q1,2 : 2SC460(B)
 D1,2,4,5,6 : 1S1555
 D3 : 1SV53A
 Q3 : 2SC1959(Y)

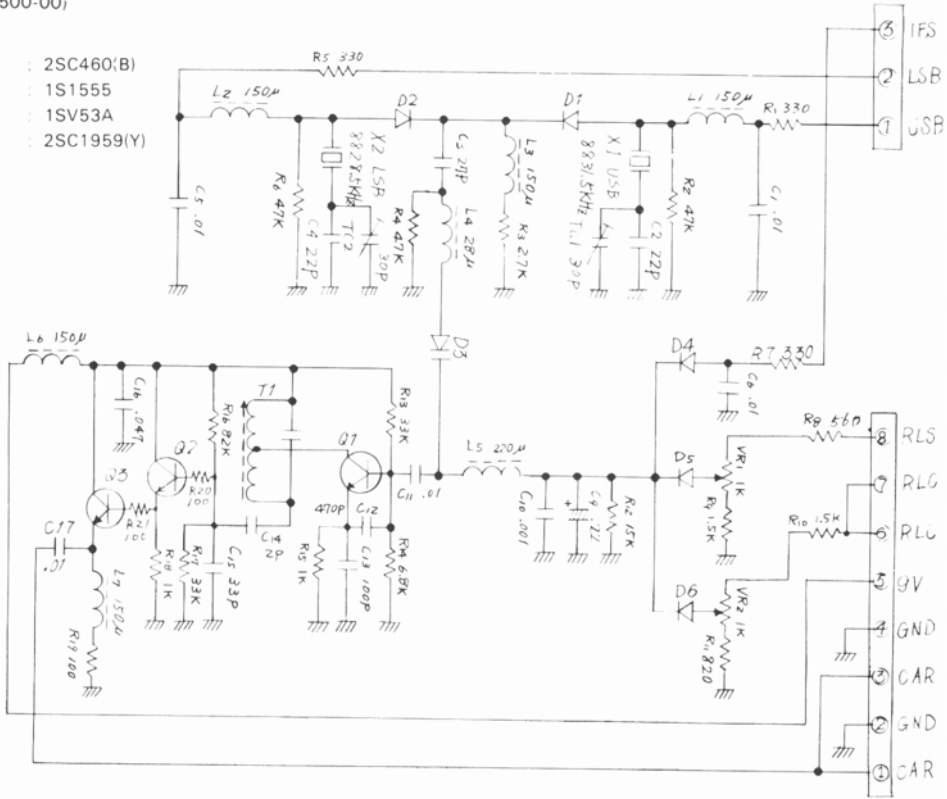

VFO UNIT (X40-1130-00)

- Q1 : 3SK22(Y) Q3 : 2SC460(B) D3 : 1SV53A
 Q2 : 2SK19(Y) Q4 : 2SC1959(Y) D4 : 1S2588

